

Technical Specifications

- Heavy duty galvanized steel propeller
- Cast aluminum drive assembly with 7 year limited bearing warranty
- Galvanized steel housing and discharge cone
- Option of plastic or aluminum inlet shutter
- Single or three phase high efficiency motor

WF50 & WF54 Fans

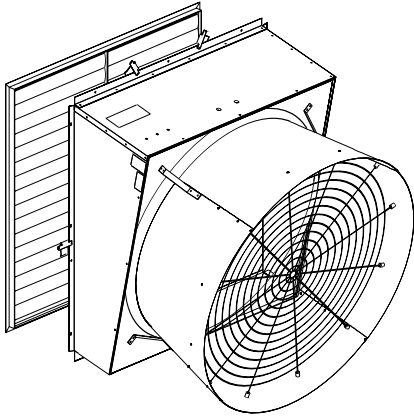

WF50 with C style cone / WF54 with CE style cone

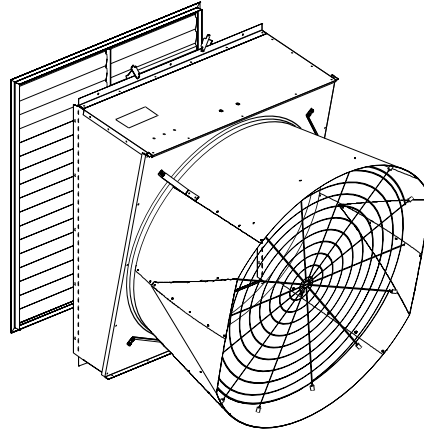

WF54 with C or CX style cone



Dimensional Data:

Fan Size	Cone Type	A	B	C	D	Cone Height	Cone Width	Wall Opening* (W.O.)
50"	C	59 ³ / ₈ "	46 ¹ / ₂ "	21 ⁵ / ₁₆ "	9 ³ / ₄ "	59 ¹ / ₁₆ "	59 ¹ / ₁₆ "	55"W x 56 ¹ / ₄ "H
54"	C	65 ¹ / ₂ "	53 ¹¹ / ₁₆ "	22 ⁵ / ₈ "	11 ¹¹ / ₁₆ "	65"	59 ¹ / ₂ "	56 ¹ / ₂ "W x 62 ¹ / ₂ "H
54"	CE	65 ¹ / ₂ "	63 ³ / ₈ "	22 ⁵ / ₈ "	15 ³ / ₈ "	70"	70"	56 ¹ / ₂ "W x 62 ¹ / ₂ "H
54"	CX	65 ¹ / ₂ "	63 ³ / ₈ "	22 ⁵ / ₈ "	15 ³ / ₈ "	70"	59 ¹ / ₂ "	56 ¹ / ₂ "W x 62 ¹ / ₂ "H

*Opening based on 2 x 4 framing. Opening size may change with framing type. Contact office for information.

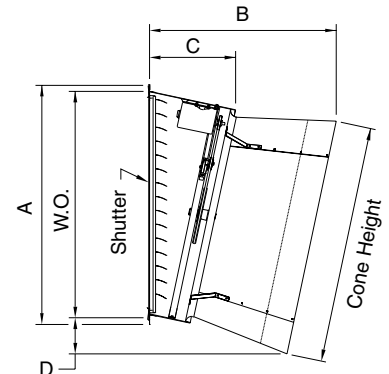

Technical Data: 60Hz shown (50Hz available)

Size	Drive	Speed	HP	Phase	Voltage	SF	SF Amps	Prop. RPM
50"	Belt	SS	1	1	208-230/110-115	1.4	6.6-6.0/13.2-11.9	460
50"	Belt	SS or FQ	1	3	460/200-230	1.3	2.0/4.2-4.0	460
50"	Belt	SS	1-1/2	1	230/115	1.0	8.5/17.0	515
50"	Belt	SS or FQ	1-1/2	3	460/208-230	1.15	2.4/4.8-4.8	515
54"	Belt	SS	1	1	208-230/110-115	1.4	6.6-6.0/13.2-11.9	515
54"	Belt	SS or FQ	1	3	460/200-230	1.3	2.0/4.2-4.0	515
54"	Belt	SS	1-1/2	1	230/115	1.0	8.5/17.0	555
54"	Belt	SS or FQ	1-1/2	3	460/208-230	1.15	2.4/4.8-4.8	555
54"	Belt	SS	2	1	208-230/115	1.2	13.8-11.3/22.6	585
54"	Belt	SS or FQ	2	3	460/200-230	1.2	3.3/7.1-6.6	585

Abbreviations:

SS = Single Speed
 FQ = Frequency Drive Control
 SF = Service Factor
 SF Amps = Service Factor Amps

Technical Specifications

Performance Data:

Fan complete with round discharge cone, guard and inlet shutter													
Catalog No.	Max BHP	0.0" SP		0.05" SP		0.10" SP		0.125" SP		0.15" SP		0.20" SP	
		CFM	CFM/Watt	CFM	CFM/Watt	CFM	CFM/Watt	CFM	CFM/Watt	CFM	CFM/Watt	CFM	CFM/Watt
WF501TCP	1.27	25,400	25.1	23,900	22.5	22,400	20.1	21,400	18.8	20,400	17.5	17,900	14.8
WF501TCJ	1.28	26,000	23.5	24,200	21.2	22,200	19.0	21,200	18.0	20,200	16.9	17,700	14.6
WF501TCY	1.27	25,300	24.5	23,900	22.1	22,400	19.8	21,600	18.8	20,700	17.7	18,700	15.5
WF5015TCP	1.74	28,000	19.6	27,000	18.0	25,800	16.4	25,100	15.7	24,400	14.9	23,000	13.5
WF5015TCJ	1.72	28,500	19.0	27,100	17.5	25,100	15.9	24,400	15.3	23,600	14.6	21,600	13.1
WF5015TCY	1.80	28,100	18.6	27,100	17.1	25,800	15.6	25,200	15.0	24,500	14.3	23,100	13.0
WF541TCEP	1.36	28,900	26.6	27,400	24.2	25,600	21.7	24,500	20.5	23,400	18.8	20,700	15.9
WF541TCEJ	1.35	29,500	28.2	27,800	25.0	26,000	22.3	25,000	21.0	23,900	19.6	21,300	16.8
WF5415TCEP	1.72	31,100	23.2	29,500	21.2	27,800	19.2	27,000	18.2	26,000	17.2	23,800	15.1
WF5415TCEJ	1.70	31,900	24.5	30,300	22.2	28,600	20.0	27,700	19.0	26,700	17.8	24,500	15.7

Fan complete with flat side discharge cone, guard and inlet shutter													
Catalog No.	Max BHP	0.0 SP"		0.05" SP		0.10" SP		0.125" SP		0.15" SP		0.20" SP	
		CFM	CFM/Watt	CFM	CFM/Watt	CFM	CFM/Watt	CFM	CFM/Watt	CFM	CFM/Watt	CFM	CFM/Watt
WF541TCP	1.40	29,100	26.0	27,400	23.3	25,500	20.6	24,500	19.3	23,400	18.0	20,700	15.3
WF541TCJ	1.37	28,900	26.2	27,300	23.6	25,400	20.9	24,400	19.7	23,400	18.5	20,900	15.9
WF5415TCP	1.73	31,500	23.3	29,700	21.1	27,800	18.8	26,900	17.8	25,900	16.7	23,600	14.6
WF5415TCJ	1.72	31,200	23.2	29,500	20.8	27,900	18.9	27,000	17.9	26,000	16.8	23,900	14.9
WF542TCP	2.05	32,500	21.1	31,200	19.5	29,800	17.9	29,000	17.0	28,100	16.2	26,200	14.6
WF542TCJ	2.10	32,300	20.4	30,800	18.6	29,000	16.7	28,150	16.0	27,300	15.3	25,500	13.9

1. The ratings shown are based on tests and procedures performed at the BESS Lab, University of Illinois in accordance with ASHRAE Standard 51-1999.
2. BHP values were not measured at the BESS Lab. The BHP values shown were derived from actual Watt measurements using motor efficiency values supplied by the motor manufacturers.

WP-TS15 © Copyright December 2006